



93' MID MOUNT PLATFORM AUSTIN FIRE DEPARTMENT, TX

TRUCK #L220106



DIMENSIONS

- Overall Height: 10' 10"
- Overall Length: 47' 3"

CHASSIS

- Spartan Gladiator LFD 5" Raised Roof
- Front Axle GAWR: 23,000 lbs.
Rear GAWR: 58,000 lbs.
- Cummins X15 605HP Engine
- Allison 4000 EVS Transmission
- Seating Capacity: 4
- Advanced Protection System®
- Advanced Climate Control
- 68 gallon Fuel Tank
- Michellen Tires
- 248" Wheelbase
- 21" Severe Duty Front Bumper
- Bostrom Seats
- Internal EMS Compartments

BODY

- 3/16" Aluminum Body
- Vibra Torque Body Mounting System
- Rom Roll-up Doors
- On-Scene LED Compartment Lighting
- Wheel Well Smart Storage
- Duo-Safety Ladder Package: (1) 35' 2-Section Aluminum Ladder (1) 28' 2-Section Aluminum Ladder (1) 24' 2-Section Aluminum Ladder, (2) 16' Roof Ladder, (1) 14' Roof Ladder, (1) 10' Attic Ladder (1) Little Giant 17A Ladder
- (6) Pike Pole Storage
- Whelen Lighting Package
- Rear View Camera System

AERIAL

- Ladder Tower 93' HD Mid-Mount Aerial Platform
- 100,000# Tinsel Strength Steel Aerial
- Two (2) "H" Style Outriggers With A 16' Outrigger Spread
- 5 Section Ladder Design
- Modular Platform Design
- 29 sq. ft Platform Work Area
- -10° to 78° Elevation Range
- 88 ft. 6 in. Horizontal Reach
- 1000 lbs. Dry / 500 lbs. Wet Unrestricted Tip-Load
- 2,000 GPM Flow Capacity

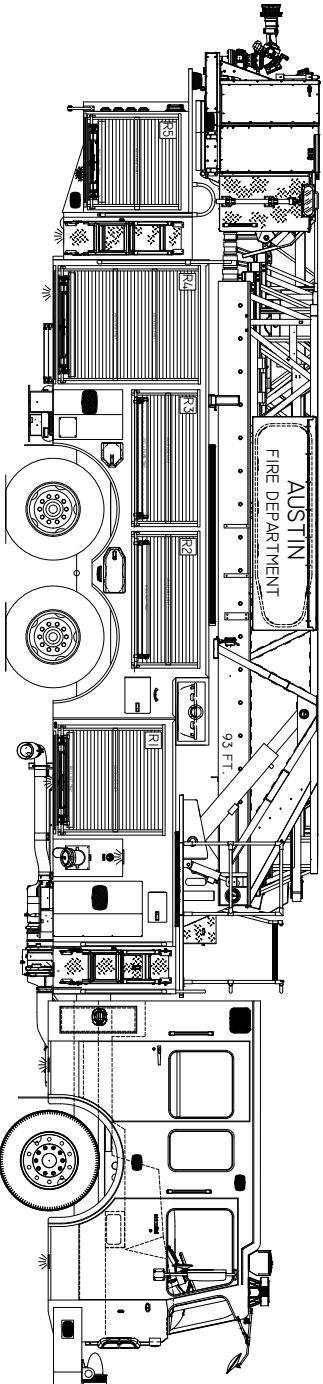
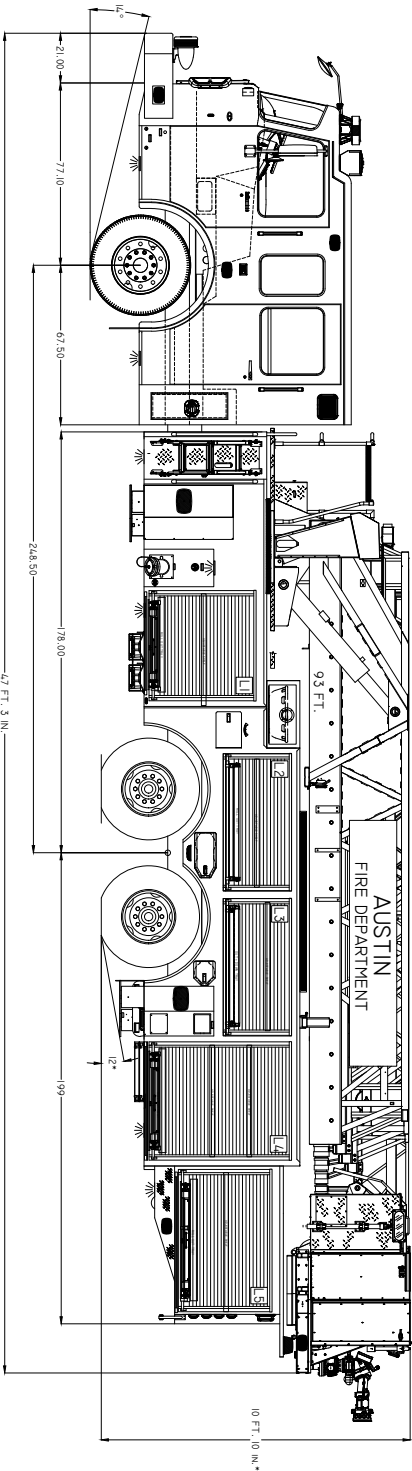
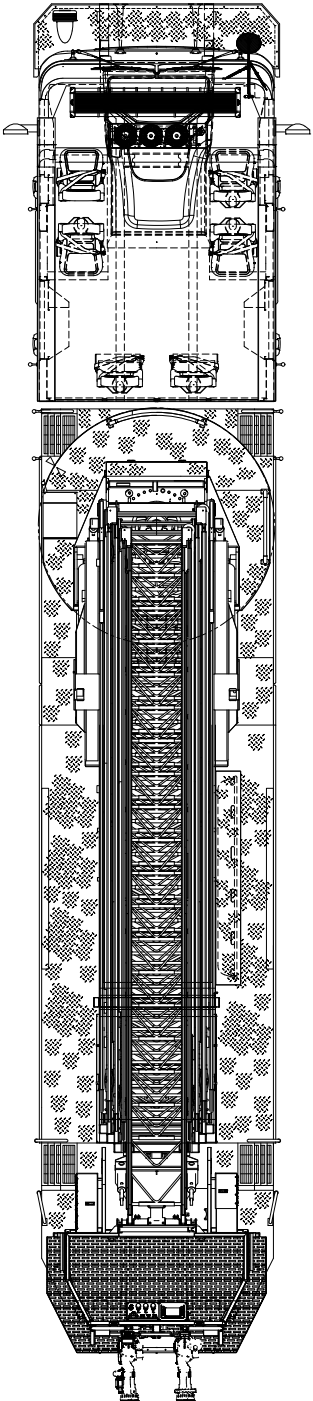
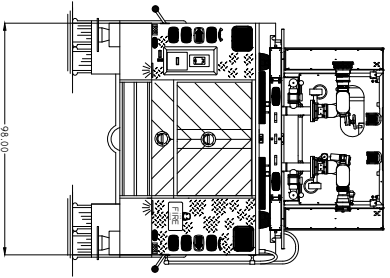
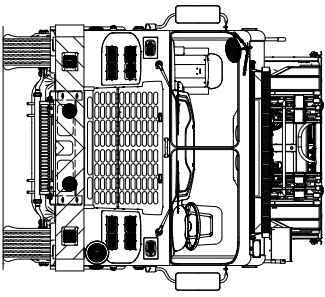
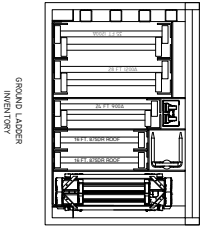

*NOTE: THE OVERALL HEIGHT OF 10 FT. 10 INCHES REPRESENTS A 10 FT. 8 IN. BODY AND AERIAL CONFIGURATION WITH 2-1/4" TALLER SUSPENSION AIR BAGS THAN STANDARD FOR IMPROVED GROUND CLEARANCE..